

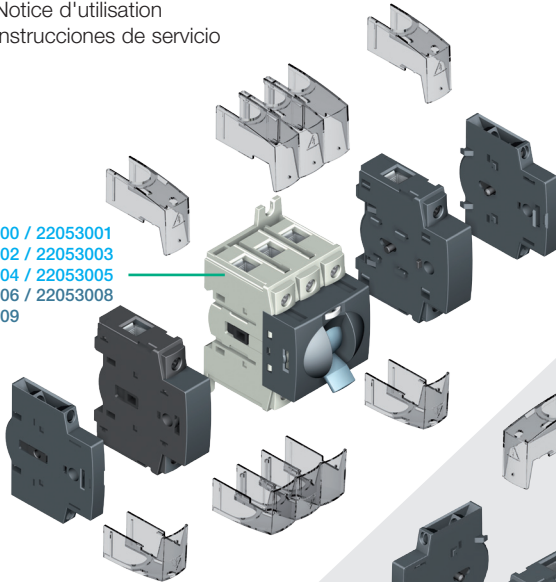

- GB Instruction sheet
- F Notice d'utilisation
- E Instrucciones de servicio

22053000 / 22053001  
22053002 / 22053003  
22053004 / 22053005  
22053006 / 22053008  
22053009



147A5111 / 147B5111  
IS 533746

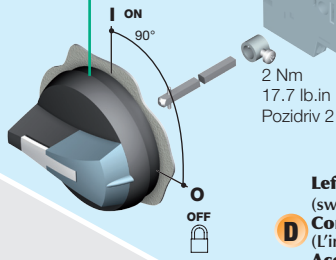

**Left side operation**  
(switch must be turned)  
**Commande latérale gauche**  
(L'interrupteur doit être retourné)  
**Accionamiento lateral izquierdo**  
(El interruptor debe ser pivotado)

22941005  
22941009

22003000 / 22003001  
22003002 / 22003003  
22003004 / 22003005  
22003006 / 22003008  
22003009

IS 533749  
22990001  
22990011

**Right side operation**  
**Commande latérale droite**  
**Accionamiento lateral derecho**

22001000 / 22001001  
22001002 / 22001003  
22001004 / 22001005  
22005005  
22009005  
22001006 / 22001008  
22001009  
22005009  
22009009

IS 533748

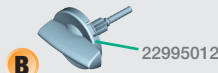

**Direct operation**  
**Commande directe**  
**Mando para accionamiento directo**

IS 533746  
14070515  
14070520  
14070532

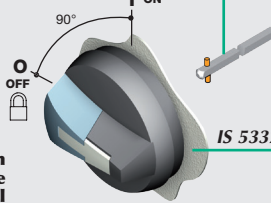

**Front operation**  
**Commande frontale**  
**Mando frontal**

22943005  
22943009

14715111 / 14711111 / 14735111 / 14745111  
14731111 / 14741111 / 147D5111 / 147D1111  
147E5111 / 147E1111  
14845111 / 148E5111 / 14835111 / 148D5111  
14841111 / 148E1111 / 14831111 / 148D1111  
14745111 / 147E5111 / 14735111 / 147D5111  
14741111 / 147E1111 / 14731111 / 147D1111

For North American market only (UL and CSA)

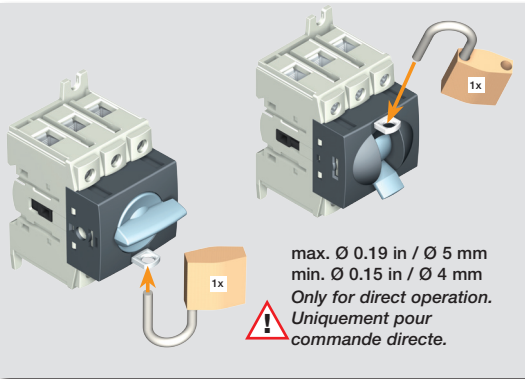

max. Ø 0.19 in / Ø 5 mm  
min. Ø 0.15 in / Ø 4 mm  
Only for direct operation.  
Uniquement pour commande directe.

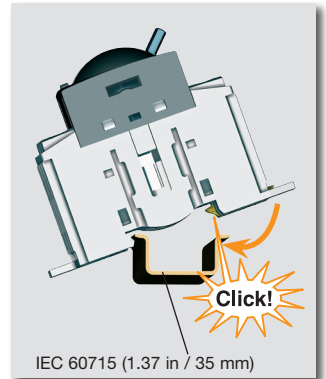
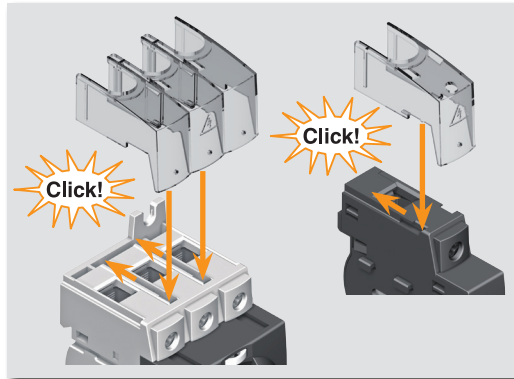

IEC 60715 (1.37 in / 35 mm)

Use copper conductors only, 75°C or higher.  
Flat 6,5  
Pozidriv 2

M16 to M40 - M CD63

Wire / Câble / Cable	Torque / Couple / Par de apriete
1,5 mm <sup>2</sup> - 16 mm <sup>2</sup>	
14 - 4 AWG stranded	
14 - 10 AWG solid	26.5 lb.in / 3 Nm
2x14 - 2x12 AWG stranded	
2x12 AWG solid	

M63 - M80 - M CD100

Wire / Câble / Cable	Torque / Couple / Par de apriete
2,5 mm <sup>2</sup> - 35 mm <sup>2</sup>	
14 - 1 AWG stranded	
14 - 10 AWG solid	31.1 lb.in / 3,5 Nm
2x10 - 2x6 AWG stranded	
2x12 AWG solid	

**WARNING / ATTENTION / PRECAUCIÓN**

The opening of the branch-circuit protective device may be an indication that a fault has been interrupted. To reduce the risk of fire or electric shock, current-carrying parts and other components of the controller should be examined and replaced if damaged.

Le déclenchement du dispositif de protection des dérivations peut signifier qu'un courant de défaut a été interrompu. Pour réduire le risque d'incendie ou de choc électrique, les pièces porteuses de courant et les autres composants de la commande doivent être vérifiés et remplacés s'ils sont endommagés.

La activación del dispositivo de protección frente a derivaciones puede significar que se ha interrumpido una corriente de fallo. Para reducir el riesgo de incendio o de choque eléctrico, las piezas portadoras de corriente y demás componentes del pedido deberán comprobarse y sustituirse en caso de que se encuentren dañados.

**HAZARDOUS VOLTAGE / PELIGRO**

HAZARDOUS VOLTAGE. This equipment must be installed and serviced only by qualified electrical personnel. Turn off all power supplying this equipment before working on or inside equipment. Always use a properly rated voltage sensing device to confirm power is off. Replace all devices, doors, and covers before turning on power to this equipment. Failure to follow these instructions will result in death or serious injury.

TENSION DANGEREUSE. L'installation et l'entretien de cet appareil ne doivent être effectués que par du personnel qualifié. Coupez l'alimentation de cet appareil avant d'y travailler. Utilisez toujours un dispositif de détection de tension à valeur nominale approprié pour confirmer que toute alimentation est coupée. Remplacez tous les dispositifs, les portes et les couvercles avant de mettre cet appareil sous tension. Si ces précautions ne sont pas respectées, cela entraînera la mort ou des blessures graves.

TENSION PELIGROSA. Solamente el personal de mantenimiento eléctrico especializado deberá instalar y prestar servicios de mantenimiento a este equipo. Desenergice el equipo antes de realizar cualquier trabajo en él. Siempre utilice un dispositivo detector de tensión adecuado para confirmar la desenergización del equipo. Vuelva a colocar todos los dispositivos, las puertas y las cubiertas antes de energizar este equipo. El incumplimiento de estas precauciones podrá causar la muerte o lesiones serias.

**Direct operation**  
**Commande directe**  
**Mando para accionamiento directo**

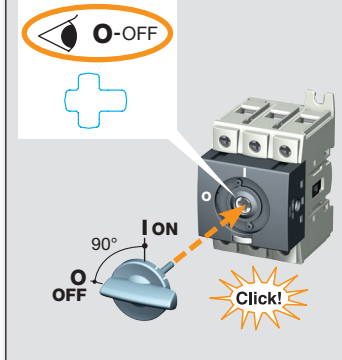

**External operation**  
**Commande extérieure**  
**Mando exterior**

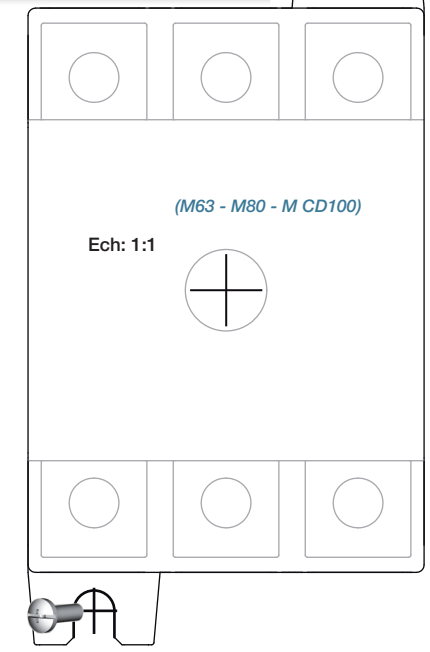
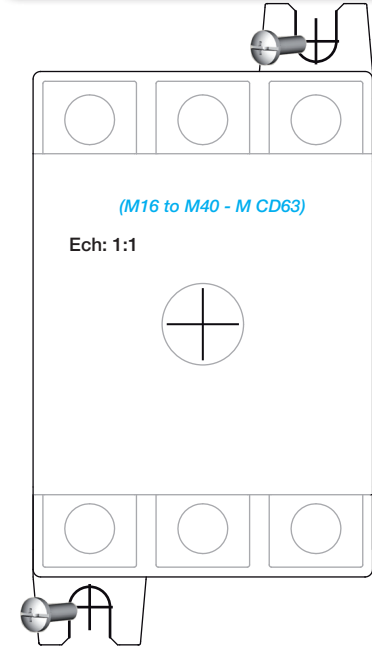
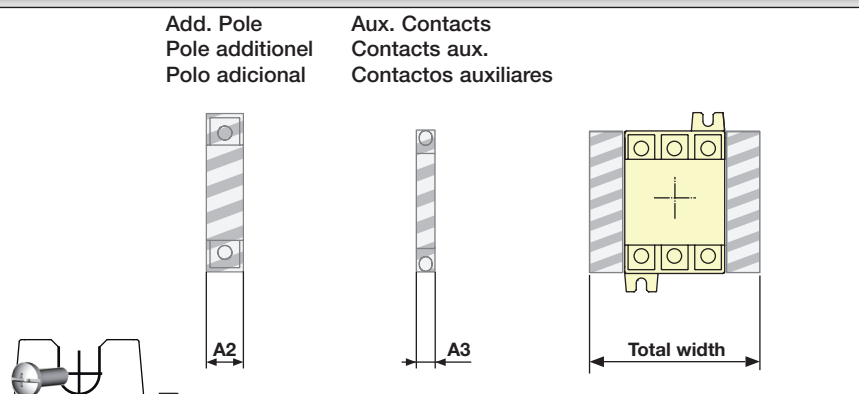
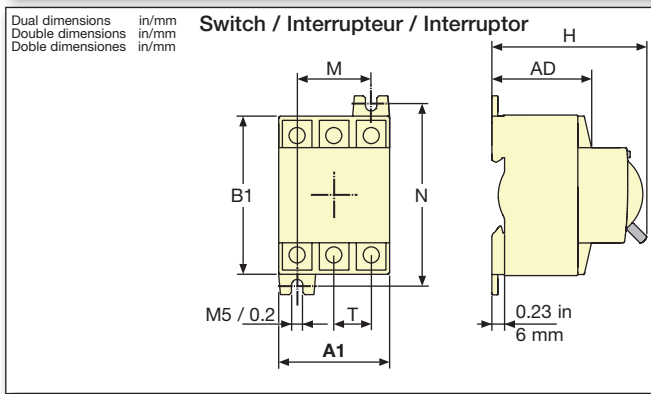
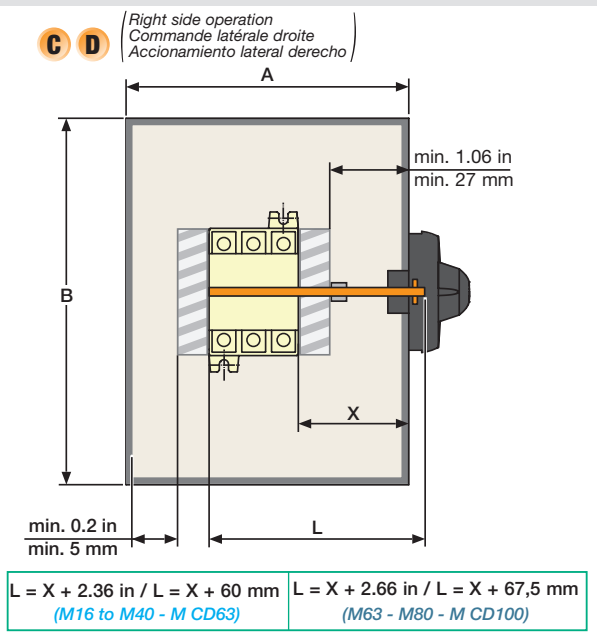
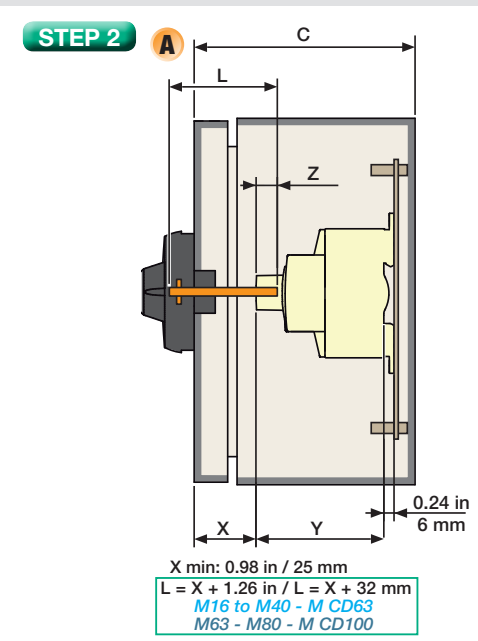
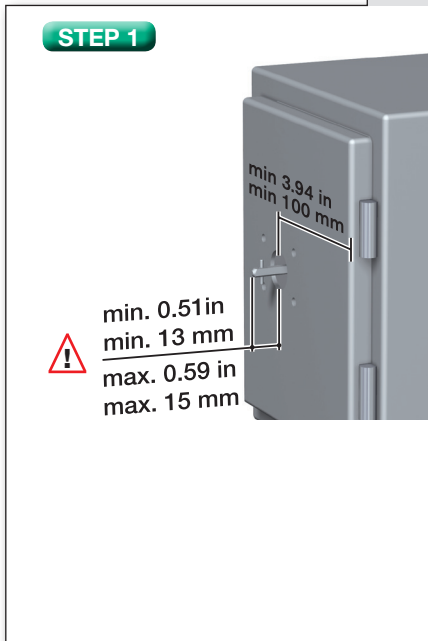
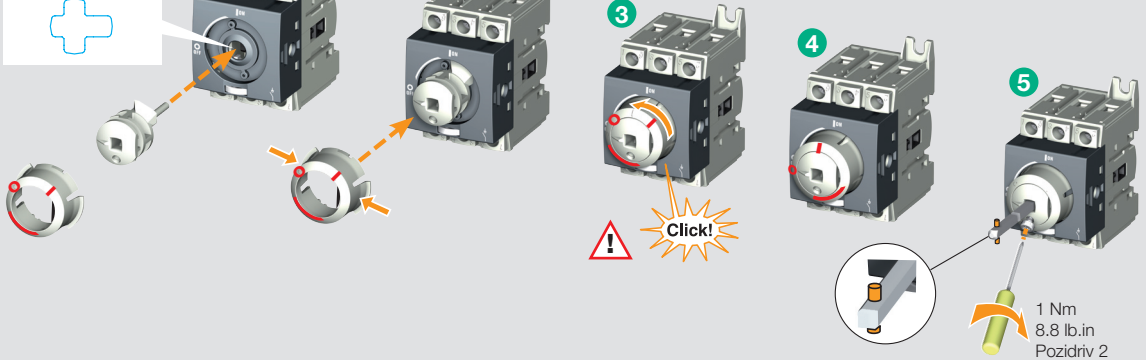

**Total width = A1 + x A2 + y A3**

if x = 0 y = 2 max  
 if x = 1 y = 2 max  
 if x = 2 y = 2 max

	M16 to M40 - M CD63		M63 - M80 - M CD100	
	in	mm	in	mm
A	6	152	8	203
A1	1.77 (2.5 x 0.70)	45 (2.5 x 18)	2.06 (3 x 0.68)	52.5 (3 x 17.5)
A2	0.59	15	0.68	17.5
A3	0.34	8.8	0.34	8.8
AD	1.90	48.5	1.90	48.5
B	8	203	10	254
B1	2.67	68	3	76
C	4	102	4	102
H	2.95	75	2.95	75
T	0.59	15	0.68	17.5
N	2.95	75	3.35	85
M	1.18	30	1.38	35
Y	2.95	75	2.95	75
Z min.	0.47	12	0.47	12
Z max.	0.67	17	0.67	17